

## FAMJ

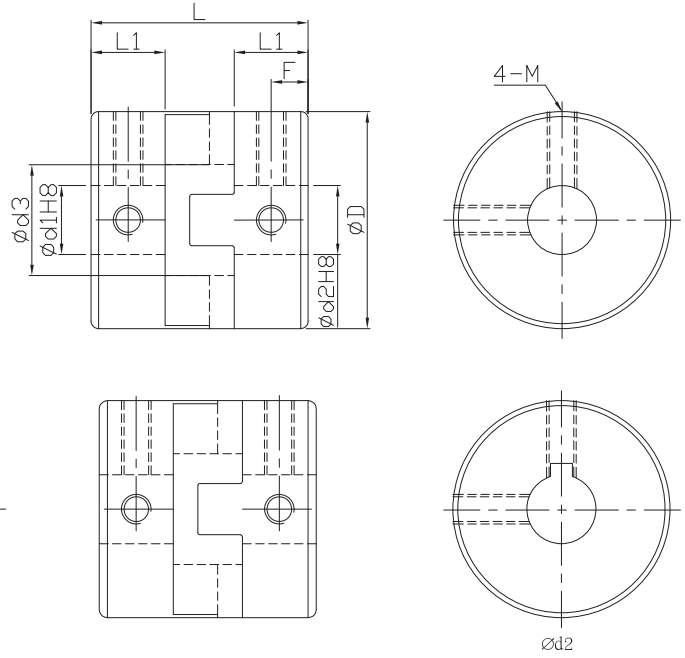

- Operating temperature : -20°C~80°C
- Offset of angular, parallel, or axial deviation are individual allowed value, so couple reasons of axial offset appearing at same time would reduce the unit allowable value.
- Available options for key way per inner diameter is bigger than 6mm. (Refer to page 39)



FAMJLK(key way Ød1 side)  
 FAMJRK (key way Ød2 side)  
 FAMJWK (key way Ød1 and Ød2 side)

Component	Material	Surface finish	Accessories
Main frame	Aluminum Alloy	Anodized	Set screw
Spacer	Black (POM)	—	

Dimensions		Ød1&Ød2 selection *Ød1 ≤ Ød2											Ød3	L	L1	F	Set screw		
Model no.	ØD	14	15	16	18	20	22	25	26	28	30	35					38	M	Lock torque (N·m)
FAMJ	44	●	●	●	●	●	●							22.5	46	15	7.5	6	7.0
	55				●	●	●	●	●					28	57	19	9.5	8	15.0
	70						●	●		●	●	●	●	39	77	25	12.5	10	30.0

★ Moment of inertial torque and weight calculated by maximum diameter.

Specification		Allowable wrench torque (N·m)	Allowable misalignment		Static torsional stiffness (N·m/rad)	Max. RPM (r/min <sup>-1</sup> )	★ Moment of inertia (kg·m <sup>2</sup> )	★ Weight (g)
Model no.	ØD		Angular (°)	Parallel (mm)				
FAMJ	44	30	2	1	1500	12000	4*10 <sup>-5</sup>	140
	55	45		1.5	2800	10000	11*10 <sup>-5</sup>	260
	70	80		2	4800	8000	40*10 <sup>-5</sup>	450

Ordering Example: FAMJ44 - 18 - 22 - 100 PCS  
 Model no. Ød1 Ød2 Q'ty